

Reavell

Gardner
Denver

HIGH PRESSURE SOLUTIONS

YOUR CUTTING EDGE

Medium and High Pressure Nitrogen
Boosters for Industrial Applications

YOUR **COMPETITIVE** EDGE



Reavell 5209N2B2

ON-SITE NITROGEN PRODUCTION IS THE INTELLIGENT CHOICE ACROSS INDUSTRY. OUR PISTON TECHNOLOGY ENSURES MAXIMUM EFFICIENCY, MAKING REAVELL THE PERFECT PARTNER FOR YOUR NITROGEN SYSTEMS.

MAXIMUM EFFICIENCY, MINIMUM NITROGEN LOSS, AND EXTREME RELIABILITY

Ensure your competitive edge with Reavell

PERFECT WITH PRESSURE

Building on a 120 year heritage, Reavell continues to maintain its position at the leading edge of compressed air technology. The engineers behind the first Scott-Reavell steam engine, patented in 1894, probably wouldn't recognise our current high pressure compressor range, but they would certainly identify with our relentless drive for technical excellence and quality customer service.

As part of the global Gardner Denver High Pressure Division, Reavell continually invests in research and development, with the goal of continuously improving the reliability and efficiency of our machines.

Our compact compressor solutions are designed to offer market leading, maximum output with minimum size and weight. They deliver unrivalled performance and peace of mind for customers operating in some of the world's most demanding environments - at sea, on land and underground.

EFFICIENT NITROGEN BOOSTING

Reavell is a world renowned compressor manufacturer, with expertise in compressing air, inert and explosive gases. We have applied our revolutionary piston technology to ensure our nitrogen boosting compressors have maximum efficiency, minimum nitrogen loss, and extreme reliability.

So whether it's the wide ranging benefits of our piston technology, or the expertise and support you can expect from a global leader - whatever your application, you can rely on Reavell for a constant and efficient nitrogen stream.

- Laser Cutting
- Tyre Filling
- HP Injection Moulding
- Aircraft Maintenance
- Cylinder Filling
- Autoclaves



YOUR LEADING EDGE



Banner image courtesy of Newbow Aerospace, Redditch, UK

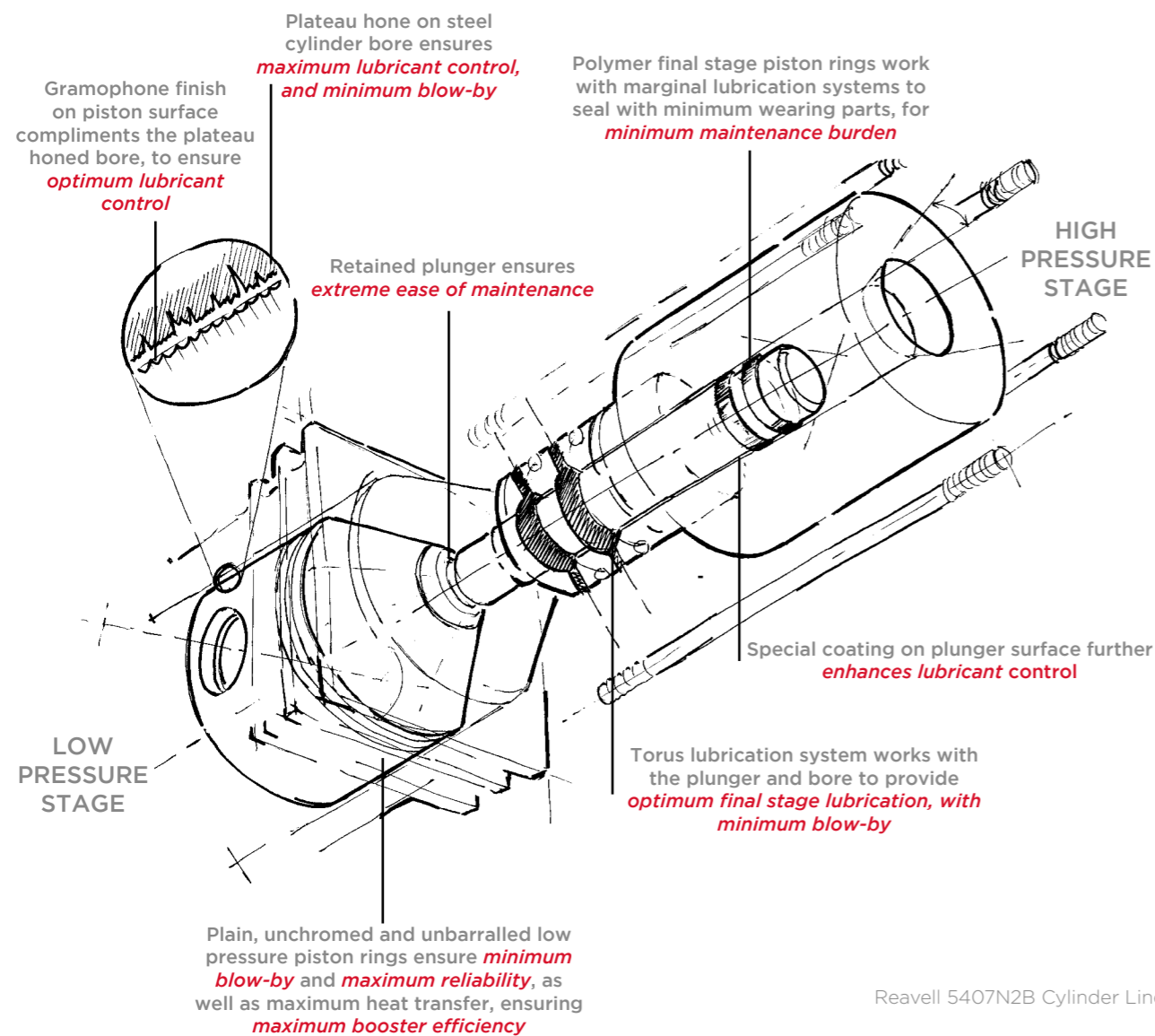

Reavell 5407N2B Cylinder Line

MAXIMUM EFFICIENCY, MINIMUM GAS LOSS

When you're processing any gas, minimising losses is critical to protecting your bottom line. That's why we've made sure Reavell nitrogen boosters offer maximum reliability, while almost eradicating gas loss.

Our low pressure stages ensure minimum piston blow-by and oil carryover, and maximum machine reliability and efficiency through the use of our own specification of iron alloy bores, plateau honed to our in house design standards, iron piston rings with optimised geometry and targeted lubrication.

But it's our high pressure stages that really set us apart from the competition. Decades of development work focussing on minimising blow-by and oil carryover, maximising reliability, and allowing extreme ease and speed of maintenance have led us to our revolutionary hardened steel, polished bores combined with polymer piston rings and our revolutionary torus lubrication system.

What's more, our unique, in-house, surface finish standards, the optimised geometry and materials of our piston rings, and our relentless focus on quality mean oil carryover from the booster is best in class at 3ppm, maximising downstream filter life and minimising compressor oil consumption.

YOUR TOTAL EDGE



GARDNER DENVER - ONEAIR SOLUTIONS

At Gardner Denver our industry leading boosters are only part of the story, we have all your nitrogen generation and boosting requirements covered. Whether it's low pressure air compression and treatment, nitrogen generation and processing, boosting up to 414 barg or high pressure nitrogen filtration, we have the equipment for you.

With proven solutions installed and supported globally, you can rely on Gardner Denver as your single source solution provider. Be sure that with a Reavell compressor, we've got you covered.



MODEL		DRIVE OPTIONS		SUCTION PRESSURE RANGE		DELIVERY PRESSURE RANGE		SPECIFIC PERFORMANCE	
								POWER	FLOW RATE
Block	Speed	Direct Drive	Belt Drive	Min barg	Max barg	Min barg	Max barg	kW	m³/hr
MEDIUM PRESSURE									
5209N2B	1000	○	●	4.0	6.0	15	40	2.9	23.7
	1200	○	●	4.0	6.0	15	40	3.5	28.5
	1500	○	●	4.0	6.0	15	40	4.2	32.5
	1800	○	●	4.0	6.0	15	40	5.1	39.0
5209N2B2	1000	○	●	4.0	6.0	15	40	5.7	47.3
	1200	○	●	4.0	6.0	15	40	6.8	56.8
	1500	○	●	4.0	6.0	15	40	8.7	67.5
	1800	○	●	4.0	6.0	15	40	10.5	81.0
HIGH PRESSURE									
5407N2B	900	-	●	2.5	6.0	120	414	4.0	14.2
	1200	-	●	2.5	6.0	120	414	5.3	18.8
	1500	-	●	2.5	6.0	120	414	6.6	23.4
	1800	-	●	2.5	6.0	120	350	8.0	27.9
5409N2B	900	-	●	2.5	4.0	120	350	10.7	30.5
	1200	-	●	2.5	4.0	120	350	14.1	40.5
	1500	-	●	2.5	4.0	120	350	17.6	50.3

Medium pressure specific performance shown at 5.5 barg inlet and 40 barg delivery pressure
High pressure specific performance shown at 5 barg (5407) and 4 barg (5409) inlet and 300 barg delivery pressure

ONEAIR SOLUTIONS	
Low Pressure Air Compressors	ESM Series Lubricated Screw EnviroAire Series Oil Free Screw EnviroAire Series Oil Free Scroll
Low Pressure Air Filtration	GDF Range
Oil Vapour Removal	GDFT Range
Air Dryers	GDD Refrigeration Range GDY Adsorption Range GDDT Hybrid Range
Low Pressure Storage	VR Vertical Range HR Horizontal Range
Nitrogen Generators	GDN2 Range
High Pressure Nitrogen Booster	GDN2B Range
High Pressure Nitrogen Filters	GDHF Range
HSK1201	HSK1228
High Pressure Storage	HPS Range



YOUR **SUPPORTIVE** EDGE

REAVELL - YOUR SPECIALIST PARTNER

At Reavell we value our partners, and we know that every successful partnership is unique.

Speak to your local Reavell sales representative about the nitrogen solutions available within the Gardner Denver family.

REAVELL TRAINING DAYS

Reavell have supplied high pressure piston compressors for over 100 years. And not only that, throughout our history we have offered solutions at every level of industry, supplying air ends to OEMs, semi complete packages to integrators, and complete turnkey packages to end users.

This unique position means we understand the market requirements and challenges faced at every level. So our unique nitrogen boosters offer you the flexibility to develop a system unique to your brand, but with all of the reliability of a premium nitrogen booster built in - that's why all of our boosters can be delivered with extra or modified equipment to ensure they fit into your system as efficiently as possible.

What's more, our engineers have minimised the module footprint, giving you maximum freedom to ensure your system is lightweight, compact, and includes plenty of space for maintenance.

Speak to your local Reavell sales representative today to find out more about our range of world class nitrogen boosters.

FACTORY REFURBISHMENT CENTRE

Depending on the planned lifetime of your systems, replacing compressor units is not always a suitable option. Our factory refurbishment centre has supported key customers across industry and military applications for decades, so you can be sure that with Reavell - your total system will be supported for it's life.

REAVELL TRAINING DAYS

At Reavell we're proud of our products - and we like to show them off!

Our range of factory training days cover everything from important health and safety considerations and nitrogen basics right up to in depth machine maintenance training and market and application focussed sales training.

What's more, because we value our partners we can design a bespoke training course around your requirements. So whether it's sales training centered on technical features and USPs or hands-on maintenance training for your engineers, we can offer the course for you.

All supported by our brand new factory training centre, opened in 2017, and available at a time and place that suits you, speak to your local Reavell sales representative today to book your place.



YOUR SPECIALIST EDGE

QUALITY - WHEN IT MATTERS MOST

At Reavell we aren't like other nitrogen booster manufacturers, we support specialist compressed air and gas requirements across industry, and that means we can offer you more.

All of our boosters are designed and manufactured in our factory in the UK, meaning we don't purchase 3rd party compressor

components or sub-assemblies. Because we design and specify every component to our exacting standards we know the limits of our machines, and we're happy to take our nitrogen boosters further than anyone else - whether it's explosive environments, sub-zero temperatures, or any other critical application, you can be sure that with a Reavell booster, we've got you covered.

ATEX Certified

All booster designs have been ATEX assessed, and can be supplied with ATEX certification and a temperature rating of T2

3.1 Material Certificates

For critical applications, 3.1 material certificates are available on pressure retaining parts across the range, giving complete material traceability

Operation Below 0°C Ambient

All boosters can operate at ambient temperatures down to -10oC, with sump heaters available on all models rated above 5 kW

SERVICING AND MAINTENANCE

Maintaining your investment is an important consideration, and with a Reavell compressor you can be sure you've got the edge over the competition.

Our compressors come with service kits designed to minimise costs, covering minor air end servicing, right down to running gear overhauls.

	OIL CHANGE	MINOR 1	MINOR 2	MINOR 3	MAJOR
5209N2B	HSK1503	HSK6556	HSK6580	-	HSK6599
5209N2B2	HSK1503	HSK6556	HSK6564	-	HSK6572
5407N2B	HSK5207	HSK4839	HSK4847	HSK4863	HSK4871
5409N2B	HSK1392	HSK4219	HSK4227	HSK4243	HSK4251

YOUR CUTTING EDGE

Medium and High Pressure Nitrogen Boosters for Industrial Applications

PERFECT WITH PRESSURE

Minimum nitrogen loss, maximum efficiency, and extreme reliability. Ensure your competitive edge with Reavell.

MAXIMUM PISTON EFFICIENCY

- Low pressure stage design ensures maximum efficiency, minimum nitrogen loss, and extreme reliability.
- High pressure stage design ensures minimum blow-by and oil consumption, maximum reliability, fewer wearing parts and extreme ease of maintenance.

SPECIALIST SUPPORT

- Additional products available to enhance your nitrogen systems.
- Bespoke training packages.

INDUSTRY LEADING EXPERTISE

- ATEX certified, 3.1 Material certificates, operation below 0°C ambient.

oneair™

SINGLE SOURCE
INDUSTRIAL
AIR SOLUTIONS

For more than 155 years, Gardner Denver has been a leading global provider of compressors, blowers and vacuum pumps. OEMs and end-users from every corner of the world rely on us for their business solutions.

With global teamwork, strong customer focus, and vast application knowledge, our brands provide reliable, energy-efficient products that serve a wide range of manufacturing and process industries.

GARDNER DENVER REAVELL OFFER SOLUTIONS FOR:



BREATHING
AIR



BREATHING
GAS



NITROGEN
BOOSTING



CNG &
BIOGAS



ENGINE
START



INDUSTRIAL
AIR & GAS



MARINE
& OFFSHORE



DEFENCE

CONTACT US TODAY:

GARDNER DENVER LTD

Claybrook Drive, Redditch, Worcestershire, B98 0DS, UK

T: +44 (0) 1527 838 600 | F: +44 (0) 1527 838 630

E: highpressure@gardnerdenver.com

www.gardnerdenver.com/highpressure

